

Snapshot

The **OptiSoft Water Softener Model OS.20** is designed to remove or reduce calcium and magnesium “hardness” minerals from water eliminating problems associated with the formation and accumulation of scale deposits. Scale forming minerals can be removed through ion exchange. For applications where a managed amount of hardness minerals is desired, the OptiSoft OS.20 is equipped with precision blending allowing the operator to reliably customize the amount of hardness in the treated water. The system utilizes an electronic controller for simple set-up and user interface. The OS.20 is suitable for both cold and/or hot water up to 149°F.

System Benefits

- Removes hardness minerals that cause scale formation in equipment and spotting on dishes, glasses and flatware.
- Prevents scale build-up on elements and wetted surfaces.
- Reduces maintenance frequency and cost, and extends equipment life.
- Compact, space-saving design allows system to be placed under counter or workspace.
- Heat tolerant and corrosion resistant vinyl ester tanks and high temperature strong-acid-based ion exchange resin provides years of performance without compromise at water temperatures up to 149°F (65°C).
- Electronic control valve is easily set to water hardness level for automatic, volume-initiated regeneration and interruption free service along with water and salt savings.
- Integrated Bypass Valve Assembly includes; precision blending valve, non-return check valves and 3/4" MNPT I/O.
- Includes two 3/4" FNPT x 24" long, stainless steel Flex Connectors.

ITEM #: _____ QTY: _____
JOB NAME/NUMBER _____



Application

Can be used with hot or cold feed water supplies.

Any application requiring hardness and/or iron removal or managed hardness reduction:

- Warewashing Equipment
- Tea Brewers
- Coffee Brewers

Installation Tips

- Feed-water connection to system should not exceed 149°F (65°C)
- Do not exceed system specifications for temperature and pressure.
- Protect from freezing, system should never be exposed to temperatures below 35°F (2°C)
- Detailed installation, operation & maintenance manual is included with each system.
- Installation and use **MUST** comply with all state and local plumbing codes.

► Specifications

| System | |
|---|--|
| Dimensions (Height x Width X Depth, inches) | 29-1/4" x 11" x 21.25" |
| Connection - Inlet & Outlet | 3/4" NPT female |
| Hot Water Operating Pressure <small>*Pressure over 73 psi requires regulation.</small> | 20-73* psi (1.4 -5.177 bar) |
| Cold Water Operating Pressure | 20-120 psi (1.4-8.27 bar) |
| Inlet Water Temperature Range | 35 ^o -149 ^o F (2 ^o -65 ^o C) |
| Shipping Weight | 58 lbs. |
| Electrical Connection | 120V 60Hz <small>Supplied with 24V Transformer</small> |
| Performance | |
| Nominal Hardness Reduction <small>Performance depends on operating conditions and water chemistry.</small> | 12,600 grains/Regen* |
| Service Flow Rate | 7.9 gpm (29.9 lpm) |
| Brine Tank Capacity (Salt) | 51 lbs. (23 kg) |

► Options

| Description | Item # |
|---------------------|-----------|
| Hardness Test Kit - | 180-80120 |

This product is for commercial use only and must be installed and maintained according to manufacturers guidelines.

Do not use on water that is microbiologically unsafe or of unknown quality without adequate disinfection before or after the system.

► Warranty

Systems have a 1 year warranty against defects in material and workmanship. For complete warranty information contact OptiPure customer service or go to www.optipurewater.com.

OptiPure, Mfg. by Procam Controls, Inc.
2605 Technology Dr., Bldg 300
Plano, TX 75074
p: 972.881.9797; f: 972.422.6262
www.optipurewater.com

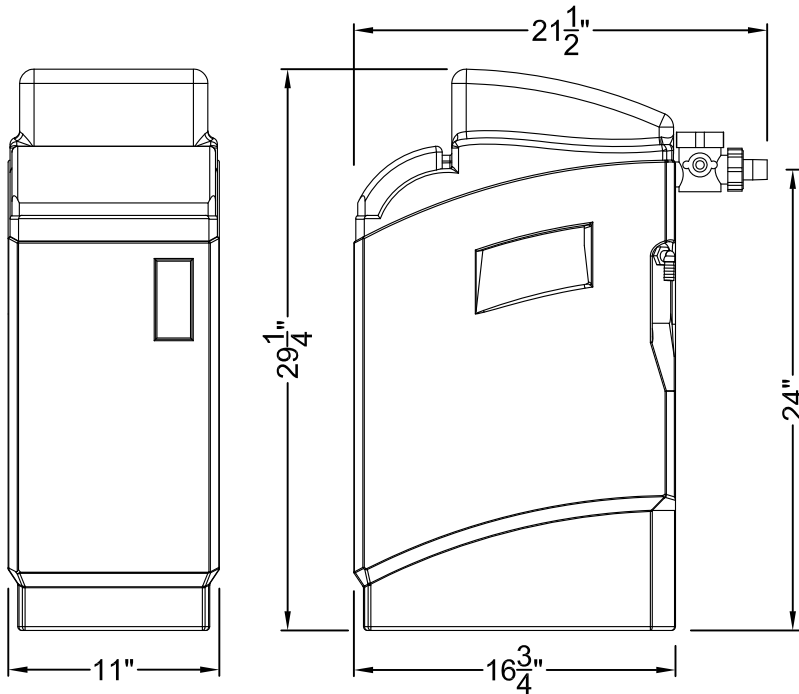

Dealer/Distributor Info: