

Snapshot

The **SX2-22B** is a dual-housing water treatment system with drop-in 4.5" x 20" cartridges that reduces sediment down to 5 microns and reduces chlorine, taste & odor at a flow rate of 4.0 gpm for 50,000 gallons. The system includes ScaleX2[®], a chemical-free scale inhibition technology that utilizes Template-Induced Crystallization to effectively inhibit the formation of calcium-carbonate scale.

System Benefits

- ScaleX2[®] protects boilers, steam generators, and coffee equipment against the formation and accumulation of scale.
- Reduces maintenance frequency and cost, and extends equipment life.
- Gradient-density sediment filtration protects against dirt, rust and other debris down to 0.5 microns.
- High-capacity activated-carbon filtration makes water taste great and protects equipment against corrosive chlorine.
- Sturdy, powder-coated mounting bracket and full-flow inlet shut-off valve simplify installation.
- Built-in pressure gauge allows visual monitoring to interpret when filters need to be changed.
- Inlet shut-off and depressurization valves make filter replacement quick and simple.
- Minimizes waste by only replacing drop-in cartridge and reusing filter sump.

ITEM #: _____ QTY: _____
JOB NAME/NUMBER _____



Application

STEAM & COMBI OVENS - *boilers or steam generators up to 4 gpm. Not recommended for 'flash' type (boilerless) combi ovens.*

TANKLESS WATER HEATERS OR CONVENTIONAL WATER HEATERS - *Up to 4 gpm.*

Installation Tips

- Feed-water connection to system should be COLD only.
- Do not exceed system specifications for temperature and pressure.
- Allow 3" clearance below system for filter housing removal and cartridge replacement.
- Connect filtered water line to ice- and steam-production connections only. Do not use for condenser water.
- Detailed installation, operation & maintenance manual included with each system.
- No activation procedure or flushing required for system to perform as specified.

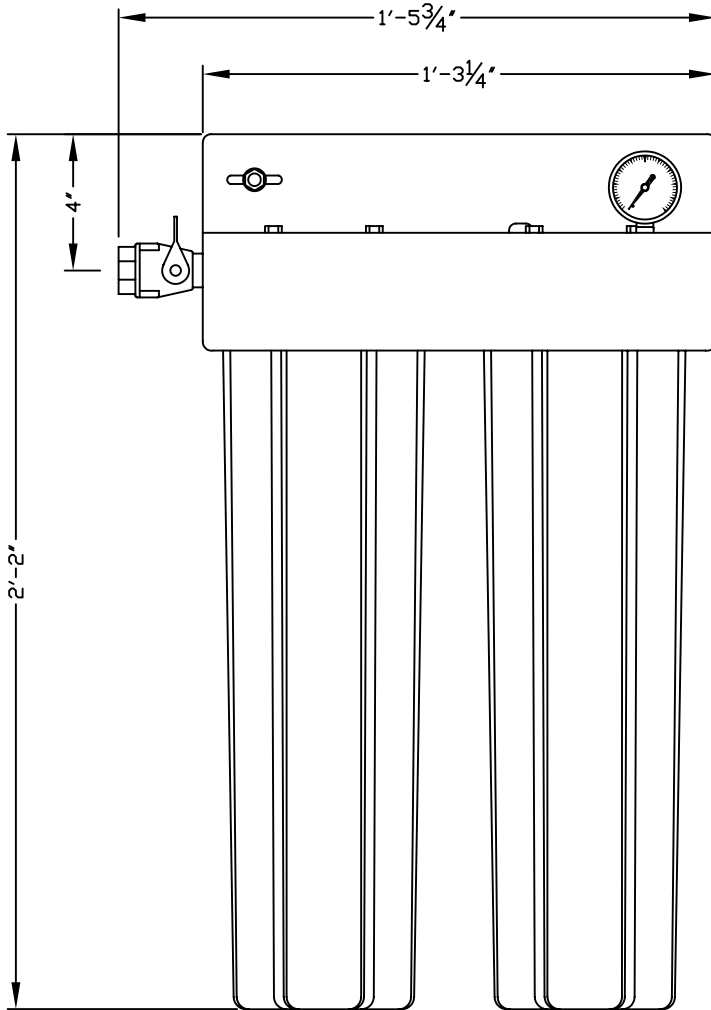

The ScaleX2 element is tested and certified by NSF International against NSF/ANSI Standard 42 for material requirements only.

Dealer/Distributor Info:

► Specifications

System	
Dimensions (Height x Width x Depth, inches)	26" x 17-3/4" x 8-1/2"
Connection - Inlet & Outlet	3/4" NPT female
Operating Pressure Range	10-125 psi (0.7 -8.6 bar)
Inlet Water Temperature Range	35 - 100°F (2 - 38°C)
Shipping Weight	24 lbs.
Performance	
Chlorine, Taste and Odor Reduction Capacity at 3 gpm	50,000 gals (189,271 liters)
Recommended Service Flow Rate for Optimum Scale Inhibition	4.0 gpm (15.1 lpm)
Sediment Reduction	5 micron (nominal)
Scale Inhibitor	ScaleX2®

Optional Flush Valve Kit - Part #: 160-52914

► Replacement Cartridge(s)

Model	Part Number	Qty
CTO-20B	252-20420	1
SCLX2-4	252-60220	1
SX22BRK*	252-60124	1

* Replacement cartridge kit includes one each of both cartridges.

It is recommended that filters be changed annually, when capacity is reached, or when effluent pressure or flow becomes inadequate.

This product is for commercial use only and must be installed and maintained according to manufacturer's guidelines.

Do not use on water that is microbiologically unsafe or of unknown quality without adequate disinfection before or after the system.

► Warranty

Systems have a 3-year warranty against defects in material and workmanship. For complete warranty information, contact OptiPure customer service.

OptiPure, a division of AQUION
2605 Technology Dr., Bldg 300 Plano, TX 75074
p: 972.881.9797; f: 972.422.6262
e: info@optipure.net www.optipurewater.com