

ITEM #: _____ QTY: _____

JOB NAME/NUMBER _____

Snapshot

The **QTI10-1** is a single-cartridge water treatment system with a 10" Quick-Twist cartridge that reduces sediment down to 0.5 microns and reduces chlorine, taste and odor at a flow rate of 1.5 gpm for 15,000 gallons. The system includes IsoNet®, OptiPure's patented scale inhibiting technology, which delivers consistent protection against the precipitation and accumulation of scale and provides a protective barrier to help guard against corrosion.

System Benefits

- IsoNet® - OptiPure's patented scale inhibiting technology helps protect equipment against scale and corrosion for the rated capacity of the system.
- Reduces maintenance frequency and cost, and extends equipment life.
- Gradient-density sediment filtration protects against dirt, rust and other debris down to 0.5 microns.
- High-capacity activated-carbon filtration makes water taste great and protects equipment against corrosive chlorine.
- Sturdy mounting bracket and full-flow inlet shut-off valve simplify installation.
- Built-in pressure gauge allows visual monitoring of when filters need to be changed.
- Inlet shut-off valve makes filter replacement quick and simple.
- Utilizes Quick-Twist cartridges that make changing filters quick, easy and sanitary.
- NSF Certified under Standard 42.



Application

ICE - Cubers up to 800 lbs and flakers up to 1,000 lbs.

COFFEE - Single or multiple brewers up to 1.5 gpm.

STEAM AND COMBI OVENS

Installation Tips

- Feed-water connection to system should be COLD only.
- Do not exceed system specifications for temperature and pressure.
- Allow 3" clearance below system for filter cartridge removal and cartridge replacement.
- Connect filtered water line to ice or steam connections only. Do not use for condenser water.
- Detailed installation, operation & maintenance manual included with each system.
- No activation procedure or flushing required for system to perform as specified.

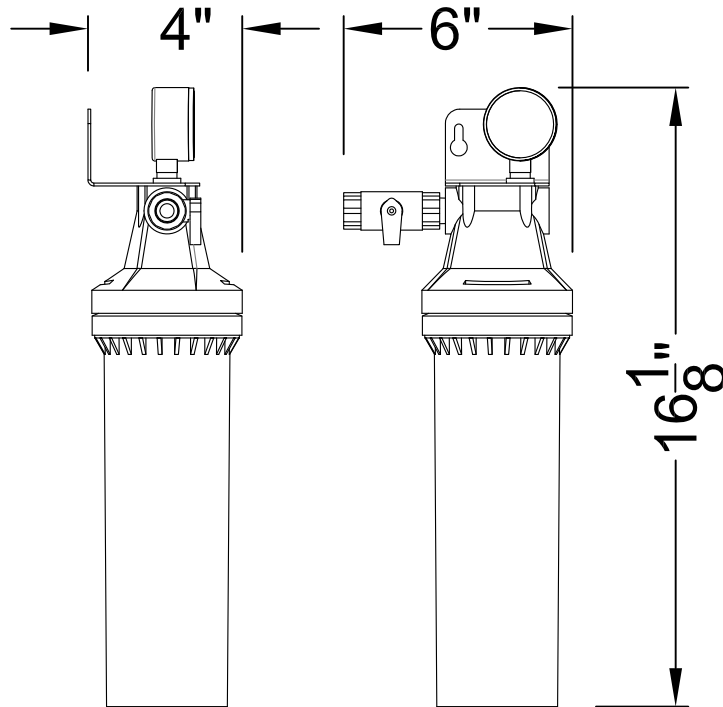

Model QT110-1 is tested and certified by NSF International against NSF/ANSI Standard 42 for:
Aesthetic Effects, Chlorine Reduction
Taste and Odor Reduction
Nominal Particulate Reduction, Class 1

Dealer/Distributor Info:

► Specifications

| System | |
|---|---------------------------------|
| Dimensions (Height x Width x Depth, inches) | 16.1" x 6" x 4" |
| Connection - Inlet & Outlet | 3/8" NFPT |
| Operating Pressure Range | 10-125 psi (0.7 -8.6 bar) |
| Inlet Water Temperature Range | 35 - 100°F (2 - 38°C) |
| Shipping Weight | 3 lbs. |
| Performance | |
| Chlorine, Taste and Odor Reduction Capacity | 15,000 gals. (56,775 liters) |
| Service Flow Rate | 1.5 gpm (5.7 lpm) |
| Sediment Reduction | 0.5 micron (nominal) |
| Scale & Corrosion Inhibitor | IsoNet (70 grams) |

Optional Flush Valve Kit - Part #: 160-52912

► Replacement Cartridge(s)

| Model | Part Number | Qty |
|----------|-------------|-----|
| CTOS-Q10 | 300-05829 | 1 |

It is recommended that filters be changed every six months, when capacity is reached or when effluent pressure or flow becomes inadequate.

This product is for commercial use only and must be installed and maintained according to manufacturer's guidelines.

Do not use on water that is microbiologically unsafe or of unknown quality without adequate disinfection before or after the system.

► Warranty

Systems have a 3-year warranty against defects in material and workmanship. For complete warranty information, contact OptiPure customer service.

OptiPure, a division of AQUION
2605 Technology Dr., Bldg 300 Plano, TX 75074
p: 972.881.9797; f: 972.422.6262
e: info@optipure.net www.optipurewater.com