

## Snapshot

The **FXI-22P** is a dual-housing water treatment system with drop-in 20" cartridges that reduces sediment down to 0.5 microns and reduces chlorine, taste & odor at a flow rate of 6.0 gpm for 60,000 gallons. The system includes IsoNet®, OptiPure's patented scale inhibiting technology, which delivers consistent protection against the precipitation and accumulation of scale and provides a protective barrier to help guard against corrosion.

## System Benefits

- IsoNet®, OptiPure's patented scale-inhibiting technology, helps protect equipment against scale and corrosion for the rated capacity of the system.
- Reduces maintenance frequency and cost, and extends equipment life.
- Gradient-density sediment filtration protects against dirt, rust and other debris down to 0.5 microns.
- High-capacity activated-carbon filtration makes water taste great and protects equipment against corrosive chlorine.
- Sturdy, powder-coated mounting bracket and full-flow inlet shut-off valve simplify installation.
- Built-in pressure gauge allows visual monitoring of when filters need to be changed.
- Inlet shut-off and depressurization valves make filter replacement quick and simple.
- Minimizes waste by only replacing drop-in cartridges and reusing filter sumps.
- NSF Certified under Standard 42.

ITEM #: \_\_\_\_\_ QTY: \_\_\_\_\_

JOB NAME/NUMBER \_\_\_\_\_



## Application

ICE - High production cubers up to 2,400 lbs. and flakers up to 4,000 lbs. daily ice production.

## Installation Tips

- Feed-water connection to system should be COLD only.
- Do not exceed system specifications for temperature and pressure.
- Allow 3" clearance below system for filter housing removal and cartridge replacement.
- Detailed installation, operation & maintenance manual included with each system.
- No activation procedure or flushing required for system to perform as specified.

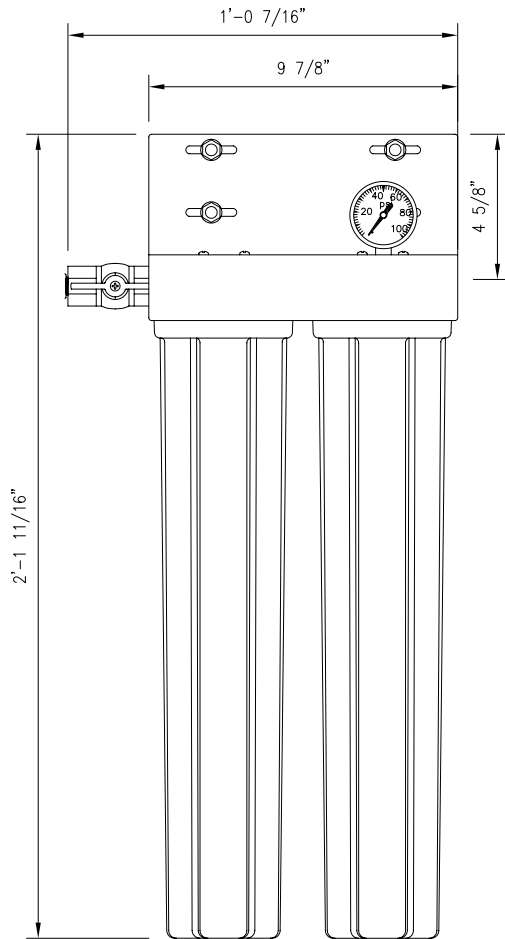

Model FXI-22P is tested and certified by NSF International against NSF/ANSI Standard 42 for:  
Aesthetic Effects, Chlorine Reduction  
Taste and Odor Reduction  
Nominal Particulate Reduction, Class 1

Dealer/Distributor Info:

## ► Specifications

System	
Dimensions Height x Width x Depth, inches	25-11/16" x 12-7/16" x 9-7/8"
Connection - Inlet & Outlet	1/2" NPT female
Operating Pressure Range	10-125 psi (0.7 -8.6 bar)
Inlet Water Temperature Range	35 - 100°F (2 - 38°C)
Shipping Weight	24 lbs.
Performance	
Chlorine, Taste and Odor Reduction Capacity	60,000 gals (227,125 liters)
Service Flow Rate	6.0 gpm (22.7 lpm)
Sediment Reduction	0.5 micron (nominal)
Scale & Corrosion Inhibitor	IsoNet (280 grams)

Optional Flush Valve Kit - Part #: 160-52910

## ► Replacement Cartridge(s)

Model	Part Number	Qty
CTOS-20	252-20220	2

It is recommended that filters be changed every six months, when capacity is reached or when effluent pressure or flow becomes inadequate.

This product is for commercial use only and must be installed and maintained according to manufacturer's guidelines.

Do not use on water that is microbiologically unsafe or of unknown quality without adequate disinfection before or after the system.

## ► Warranty

Systems have a 3-year warranty against defects in material and workmanship. For complete warranty information, contact OptiPure customer service.

**OptiPure, a division of AQUION**  
2605 Technology Dr., Bldg 300 Plano, TX 75074  
p: 972.881.9797; f: 972.422.6262  
e: info@optipure.net [www.optipurewater.com](http://www.optipurewater.com)